



PALANS A LEVIER SERIE HLB

HLB

Conforme aux normes Européennes

Les caractéristiques: Légers, compacts, robustes: pour l'industrie et les services



HLB50A



HLB75A



HLB150A

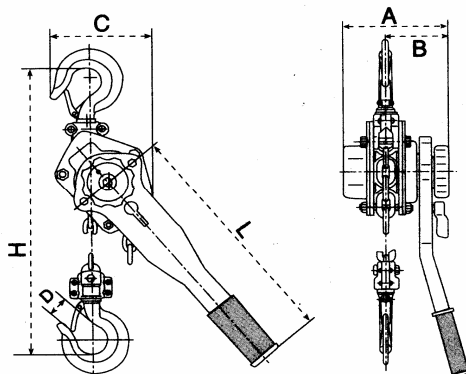

0,5 - 6 Tonnes



HLB300A



HLB600A



HLB900A

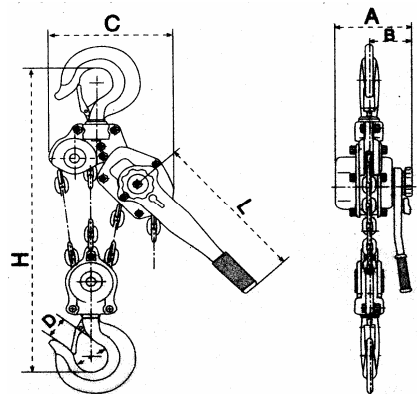

9 tonnes

Modèle		HLB50A	HLB75A	HLB150A	HLB300A	HLB600A	HLB900A
Capacité	Tonnes	0,5	0,75	1,5	3	6	9
Élévation standard	m	1,5	1,5	1,5	1,5	1,5	1,5
Effort à charge maxi	Kn	280	140	220	320	340	360
Brin chaîne élévation		1	1	1	1	2	3
Diam. chaîne éléva.	Kg	5	6	8	10	10	10
Dimensions	A mm	116	145	175	203	203	203
	B mm	86	86	100	118	118	118
	C mm	115	122	130	150	205	316
	D mm	30	37	45	50	64	85
	H mini mm	306	320	380	480	620	700
	L mm	280	280	410	410	410	410
Poids	Kg	5	7,5	11,5	21	31,5	47
Poids supp./ mètre	Kg	0,64	0,8	1,4	2,2	4,4	6,6

longueur de chaîne à la demande